

NSU 2-2 E/F ST

Foam soap dispenser with open refill system

Art.-No. 1423238



OPHARDT HYGIENE-TECHNIK GmbH + Co. KG
Lindenau 27 | 47611 Issum | Germany
Tel.: +49 (0) 28 35 18-10 | Fax +49 (0) 28 35 18-77
planer@ophardt.com | www.ophardt.com

NSU 2-2 S-D-F

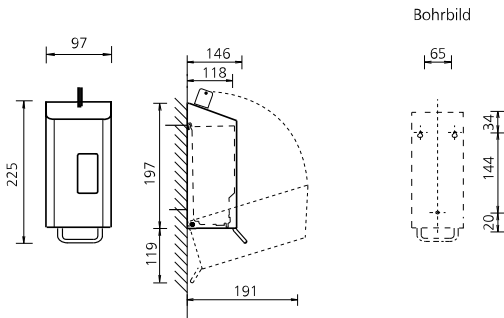

Maße in mm - Dimensions in mm



References

airports, train stations, schools, kindergardens, hotels, restaurants, commercial kitchen, food processing areas, prisons, exhibitions, conference centres, shopping centres, fitness and sports centres, industry, laboratories, administration facilities

Usage examples

washrooms, baths, nursing and examination rooms, kitchens, production facilities, entrance area

Technical data

Dispenser type:	refillable dispenser
Housing:	Stainless steel, brushed with Anti-Fingerprint-Coating (Steel Touch)
Filling volume (ml):	250 ml
Dosing pump:	long-life plastic foam soap pump
Dosage quantity:	0.7 ml/stroke
Filling good:	Foam soap
Operating type:	Stainless steel lever
with/without viewing window:	Clear
Mounting:	Wall mounting with 4 screws and wall plugs
Cleaning:	manual wipe disinfection
Warranty:	5 years
Net weight:	1.127 kg
Dimensions (W x H x D) in mm:	97x225x146
Notice:	Before using new products, please always check the compatibility of the product and the dispensing system to ensure proper functionality.

Compatible accessories

disinfection point SanTRAL	Art.-No. 1423337
High-quality hygiene stand for effective hand disinfection	
disinfection point with wheels SanTRAL	Art.-No. 1423338
High-quality hygiene stand with rolls for effective hand disinfection	

Please see other accessories in our Online Product Catalogue.