

# F3EM1012 | 2030040120

PRODUCT GROUP (PG) : Taps | ARTICLE FAMILY (AF) : Electronic tap | ARTICLE GROUP (AG) : F3EM1010 ++ |  
MODEL RANGE : F3 | LIFECYCLE : New

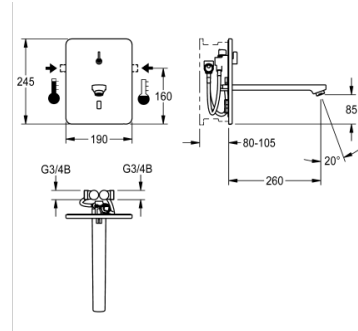

## TECHNICAL DATA

gross weight	5.23 kg
net weight	4.97 kg
functional principle	ELECTRONIX-C
type of mixing	Yes
power supply connection	BATTERY-6-V
type of mounting	in-wall installation with box
type of tap	in-wall tap
calculation flow rate cold water	0.07 liter per second
calculation flow rate hot water	0.07 liter per second
default automatic hygiene flushing	24H-AFTER-ACTIVITY
depressurised	no
diameter nominal	DN 15
material casing	stainless steel
material fitting	brass
position of power connection	from backside
power consumption	1,5
protective shutdown	YES
sound insulation	no
spout projection	260.00 mm
surface finish casing	satin finished
surface finish fitting	chromed
thermal disinfection	no
type of operation	SENSOR-OPERATION
type of sensor	OPTO-ELEC-SENSOR
volume flow rate at 3 bar	0.10 liter per second

F3EM1012 | 2030040120

PRODUCT GROUP (PG) : **Taps** | ARTICLE FAMILY (AF) : **Electronic tap** | ARTICLE GROUP (AG) : **F3EM1010 ++** |  
MODEL RANGE : **F3** | LIFECYCLE : **New**

---

## ACCESSORIES

---

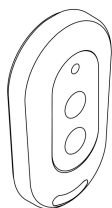
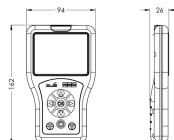

---

### REMOTE CONTROL

2030036654

---

---

### REMOTE CONTROL

2030036849

---

---

## MANDATORY ACCESSORY

---

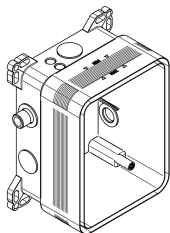

---

### BASIC INSTALLATION KIT

2030040479

---

---

## SPARE PARTS

---

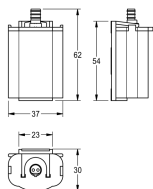

---

### BATTERY COMPARTMENT

2000109466

---